

## C Series Modular Dice Ice Machines – up to 869kg

**C 2148 MR** Dice cube 10g, 22mm x 22mm x 22mm



Dice cube 10 g  
W 22 x D 22 x H 22 mm



Note: Ice production rate is measured with the water temperature at 10°C and an ambient temperature of 21°C.

- Up to 869kg daily production rate
- Head only ice maker - requires a separate storage bin to store the ice produced
- Requires separate remote condenser
- Air cooled version
- Vertical evaporator spray-system technology
- Agion Technology resists the growth of microbes and the development of unpleasant odours
- One-touch cleaning system
- Electronic control
- Water sense adaptive purge control: saves water by adjusting water usage when is needed
- Simple, reliable electromechanic controls
- Resistant stainless steel exterior
- Easy access front condenser air filter

- External indicator lights to show operation status and maintenance alert
- Includes removable air filter, water and drain hose

#### Recommended storage bins

- NB 948 – 406kg storage capacity
- UBH 1100 – Upright storage bin with 553kg storage capacity

### C Series Modular Dice Ice Machines – up to 869kg

#### C 2148 MR

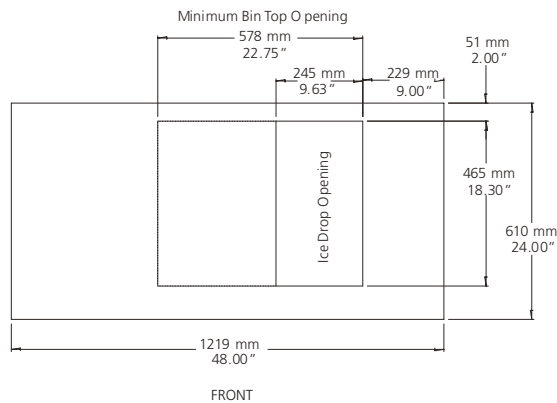
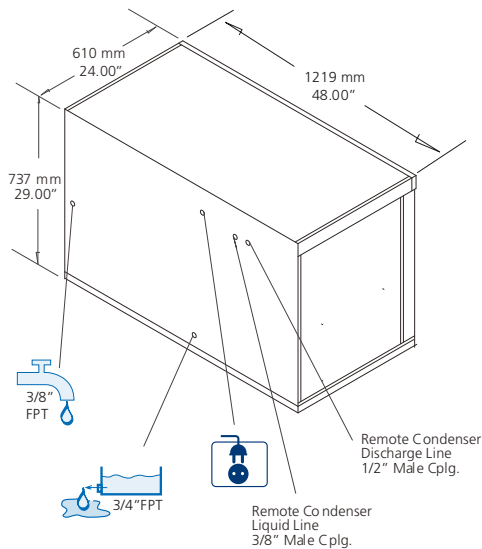

UNIT OF MEASUREMENT: mm



moffat.com.au

**Australia**  
Moffat Pty Limited  
Victoria/Tasmania  
740 Springvale Road  
Mulgrave, Victoria 3170  
Telephone 03-9518 3888  
Facsimile 03-9518 3833  
vsales@moffat.com.au

**New South Wales**  
Telephone 02-8833 4111  
nswsales@moffat.com.au

**South Australia**  
Telephone 03-9518 3888  
vsales@moffat.com.au

**Queensland**  
Telephone 07-3630 8600  
qldsales@moffat.com.au

**Western Australia**  
Telephone 08-9413 2400  
wasales@moffat.com.au

#### Ice production per 24 hours

Ambient temperature / Water temperature

10°C / 10°C	21°C / 10°C	32°C / 21°C
1020	869	697

#### Dimensions

Width: 1219mm  
Depth: 610mm  
Height: 737mm  
Nett weight: 160kg  
Packed weight: 168kg

#### Water consumption

Air cooled version: 38.5 litres per hour

#### Electrical rating

Air cooled version: 230-240V, 1P+N+E, 50Hz, 3450W,  
25A cordset supplied  
No. Circuit wire: 3  
Compressor: 3180W  
Energy consumption: 8.8kW/hr

#### Refrigerant type

R404A

#### Installation distance from wall

Rear 100mm  
Operating requirement air temperature 10-43°C

#### Water connection requirements

Inlet connection: R 3/8"  
Cold water: 5-38°C  
Pressure: 100-500kPa  
Water outlet connection: Ø3/4"

#### Important Notice:

Models and specifications are subject to change without notice. This spec sheet is meant for commercial purpose only. For technical documentation please refer to our service manuals.



© Copyright Moffat Ltd  
AU.SM.1904