

self serve
hot food bars

FOOD DISPLAY SERIES



With optional sneeze guard



Multiple element design



Quartz infra-red overhead heat lamps



Precise thermostat control

APPLICATION

Ideal for the displaying of pre-cooked foods and easy access for self serving

STANDARD FEATURES

- Includes a tapered, symmetrical, toughened glass gantry to allow access from both sides
- Stainless steel construction with dual skin air-insulated bain marie tank for improved safety
- Multiple element design means unit will continue to operate in the event of single element failure
- Thermostat controls with clear temperature readout
- 15mm drain with downward emptying tap
- Overhead heat lamps wired to maximise light, heat and reliability - with lamp guard
- Full size gastronorm cavity to take choice of 65mm and 100mm pan combinations (pans not included)
- Easy to service via rear access panel
- Identical footprint to other Woodson food bar models
- Can be run both wet and dry
- 3 bay supplied with 10 amp plug & lead
- 4, 5 & 6 bay supplied with 15 amp plug & lead

OPTIONS

Easy to accessorise:

- Rear glass sliding doors (add G to code)
- 1/2 GN pans, 65mm deep (add 65 to code)
- Trolleys & trolley accessories

SIDE VIEW

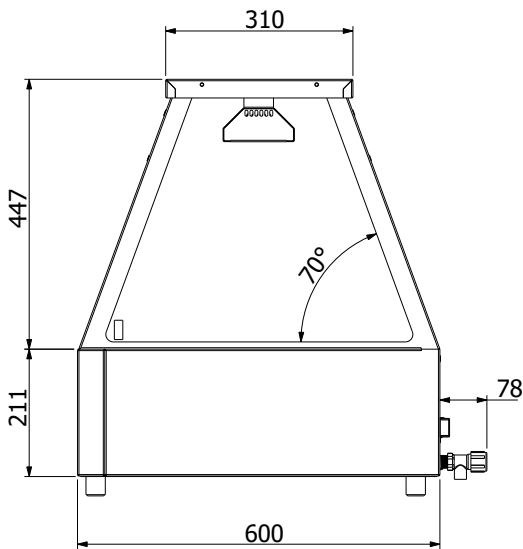

REAR VIEW

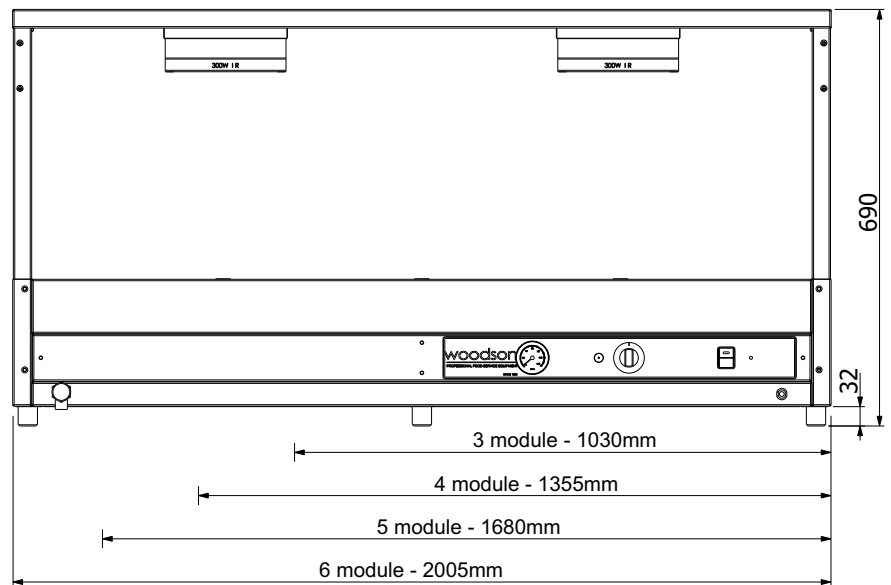

We reserve the right to alter specifications of products without notice

AVAILABLE MODELS

MODEL	Description	Dimensions (LxDxH)	Power
WHFS23SS.G	3 module unit with rear sliding glass doors	1030 x 600 x 690	2.4kW - 10 Amp
WHFS23SS.G.65	As above, with 6 x 1/2 GN pans, 65mm deep		
WHFS24SS.G	4 module unit with rear sliding glass doors	1355 x 600 x 690	3.0kW - 15 Amp
WHFS24SS.G.65	As above, with 8 x 1/2 GN pans, 65mm deep		
WHFS25SS.G	5 module unit with rear sliding glass doors	1680 x 600 x 690	3.3kW - 15 Amp
WHFS25SS.G.65	As above, with 10 x 1/2 GN pans, 65mm deep		
WHFS26SS.G	6 module unit with rear sliding glass doors	2005 x 600 x 690	3.3kW - 15 Amp
WHFS26SS.G.65	As above, with 12 x 1/2 GN pans, 65mm deep		



For details of your local dealer contact:

QLD
Tel: 07 3440 7600
Fax: 07 3344 1000
fse@stoddart.com.au

WA
Tel: 08 9414 1343
Fax: 08 9414 1361
perth@stoddart.com.au

NSW
Tel: 02 8832 4399
Fax: 02 8832 4355
sydney@stoddart.com.au

VIC & TAS
Tel: 03 9565 4699
Fax: 03 9565 4655
melbourne@stoddart.com.au

SA & NT
Tel: 1300 79 1954
adelaide@stoddart.com.au

Dealer: